

# Spider67 I/O Module

---- EtherNet/IP System Manual

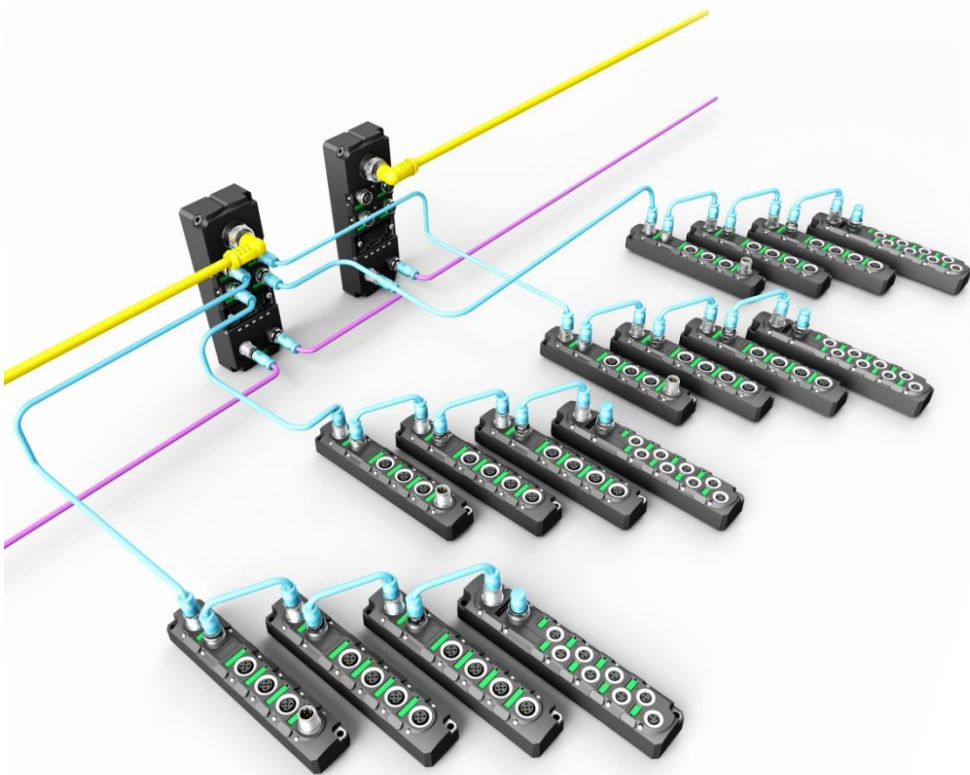

## Preface

### 1. Scope of this manual:

This manual applies to the ELCO EtherNet/IP Spider67 distributed I/O device. The information in this manual enables you to run the Spider67 module on EtherNet/IP salve mode.

### 2. Basic knowledge requirements

This manual presumes a general knowledge in the field of automation engineering and describes the components based on the data valid at the time of its release.

ELCO reserves the right of including a product information for each new component, and for each component of a later version.

### 3. Guide

This manual describes the hardware of the EtherNet/IP Spider67 distributed I/O device.

Covered topics are:

- Installation and wiring
- Commissioning and diagnostics
- Components
- Article numbers
- Technical specifications

### 4. Technical support:

This manual describes the characteristics and the usage of a Spider67 distributed I/O device.

Please contact your local ELCO representative or dial 400-608-4005 if you have any questions about the products described in this manual.

Additional information about ELCO products is available:

<http://www.elco-holding.com/>

### 5. Disclaimer of liability:

We have reviewed the contents of this publication to ensure consistency with the hardware and software described. Since variance cannot be precluded entirely, we cannot guarantee full consistency. However, the information in this publication is reviewed regularly and any necessary corrections are included in subsequent editions.

# CONTENTS

<b>PREFACE .....</b>	<b>2</b>
<b>1. PRODUCT OVERVIEW .....</b>	<b>5</b>
1.1 Introduction .....	5
1.2 Applications .....	5
1.3 Features .....	5
1.4 Type .....	6
<b>2. TECHNICAL CHARACTERISTICS .....</b>	<b>8</b>
2.1 Gateway .....	8
2.2 I/O module.....	9
2.3 Extension cable .....	10
2.4 Hardware parameters .....	11
2.4.1 Technical data of gateway .....	11
2.4.2 Digital IO Module.....	12
2.4.3 Analog IO Module.....	13
2.4.4 RTD and TC Module .....	14
2.5 LED display .....	15
<b>3. INSTALLING.....</b>	<b>17</b>
3.1 Mounting dimensions .....	17
3.1.1 Gateway dimensions .....	17
3.1.2 Module dimensions .....	18
3.2 Mounting position and dimensions .....	19
3.3 Setting the IP Address of Spider67 Gateway .....	19
3.4 Wiring Spider67 .....	22
3.4.1 Connecting Spider67 to protective earth (PE) .....	22
3.4.2 Spider67 power supply .....	22
3.4.3 Spider67 BUS connection .....	24

3.4.4 Spider67 digital signal connection .....	25
3.4.5 Spider67 analog signal .....	28
<b>4. CONFIGURATION COMMISSIONING .....</b>	<b>32</b>
4.1 Gateway assigns IP address .....	32
4.2 RSLink set up link classes .....	32
4.3 Set up network configuration .....	33
4.4 RSLogix5000 .....	35
4.5 Module startup process.....	41
<b>5. ALARM DIAGNOSIS.....</b>	<b>42</b>
5.1 LED fault indicator light .....	42
5.2 Error alarm diagnostic information.....	44
<b>APPENDIX:.....</b>	<b>45</b>
Table One: gateway control data table .....	45
Table Two: type control tables for each module .....	46
Table Three: module volume channel function configuration table .....	48
Table Four: relationship between diagnostic data and module address .....	49

## 1. Product overview

### 1.1 Introduction

Spider67 from ELCO supports modern installation methods with a new and revolutionary expandable I/O system. The simple and easy to install Fieldbus system Spider67 is especially suitable for applications in rough environments.

### 1.2 Applications

Recently, the wide-range usage of industrial fieldbus I/O products brought deep impact to the automation industry. The traditional centralized control method was replaced by intelligent distribution devices. Besides that, more devices were transferred from cabinets directly to the site. Therefore the reason lies in saving costs, reducing the operation time and shorten the maintenance period. It also optimizes the system procedure.

ELCO Spider67 exactly complies this tendency and represents a revolutionary new generation of I/O solutions. Spider67 is an expandable industrial fieldbus I/O product with protection class IP67. It supports standard industrial bus protocol gateways (such as Profibus-DP, Profinet, EtherCAT, CC-Link) and diversified extended I/O configuration modules and can easily be connected to PLC systems. Compared to the traditional IP67 I/O products, Spider67 expanded modules include digital modules, analog modules and high-speed counting modules etc. Regarding its functions, Spider67 can meet most of the requirements, e.g. processing concentrated / dispersed switch signals etc. At the same time, this product series offers flexible connection cable and can directly be mounted on a cage lifter or rotational device.

### 1.3 Features

- IP67 protection class leading to convenient mounting
- Compact design minimizes mounting space requirement
- Standard connection, fast, safe and reliable
- Various input and output signals
- Flexible I/O configuration with a combination of analog, digital, and function modules
- LED status indication, fast function diagnosis
- Can be combined with Spider67 system at random

## 1.4 Type

No.	Type	Description
1	SPEI-GW-001	EtherNet/IP substation interface module 1 male 7/8" power supply 2 female, M12 D-Code fieldbus interface 4 female, M12 B-Code extended interface
2	SPDB-0800D-001 SPDB-0800D-003	8 PNP/NPN switches or dry contact 4-female, M12 A-Code interface
3	SPDB-0800D-011 SPDB-0800D-013	8 PNP/NPN switches or dry contact 8-female, M8 interface, 3-pin
4	SPDB-0404D-001 SPDB-0404D-003	4 PNP/NPN switches or dry contact 4DI4DO, 0.5A each channel 4-female, M12 A-Code interface
5	SPDB-0404D-011 SPDB-0404D-013	4 PNP/NPN switches or dry contact 4DI4DO, 0.5A each channel 8-female, M8 interface, 3-pin
6	SPDB-08UP-001	8DI+DO, configurable 4-female, M12 A-Code interface
7	SPDB-08UP-011	8DI+DO, configurable 8-female, M8 interface, 3-pin
8	SPDB-0008D-001	8DO, 0.5A each channel 4-female, M12 A-Code interface
9	SPDB-0008D-011	8DO, 0.5A each channel 8-female, M8 interface, 3-pin
10	SPDB-0006D-001	8DO, 2A each channel 1-male, M12 A-Code interface 3-female, M12 A-Code interface
11	SPDB-0300A-001	3AI 0~20mA, 4~20mA, ±20mA optional 3-female, M12 A-Code interface
12	SPDB-0300A-002	3AI 0~10V, ±10V optional 3-female, M12 A-Code interface

13	SPDB-0003A-001	3AO 0~20mA, 4~20mA, ±20mA optional 3-female, M12 A-Code interface
14	SPDB-0003A-002	3AO 0~10V, ±10V optional 3-female, M12 A-Code interface
15	SPDB-0400A-005	4AI RTD PT100, PT200, PT500, PT1000, Ni100, Ni1000, 150/300/600/3000Ω 4-female, M12 A-Code interface
16	SPDB-0400A-006	4AI Thermocouple B, E, J, K, N, R, S, T 4-female, M12 A-Code interface
17	BB6S30P01Dxxx BB6S30P01Mxxx	Pre-wired extensible cable PVC, 5-core shielded, outer diameter 6.5mm Customized length, D=cm, M=dm
18	BB6S30P03Dxxx BB6S30P03Mxxx	Pre-wired extensible cable (drag chain) PUR, 5-core shielded, outer diameter 6.5mm Customized length, D=cm, M=dm
19	BB6S30P09Dxxx BB6S30P09Mxxx	Pre-wired extensible cable (long distance communication) PVC, 5-core shielded, outer diameter 8mm Customized length, D=cm, M=dm
20	BB6S06	Extension terminal resistance Connecting to the last I/O module

## 2. Technical characteristics

### 2.1 Gateway

The following picture is the schematic diagram of Spider67 gateway.

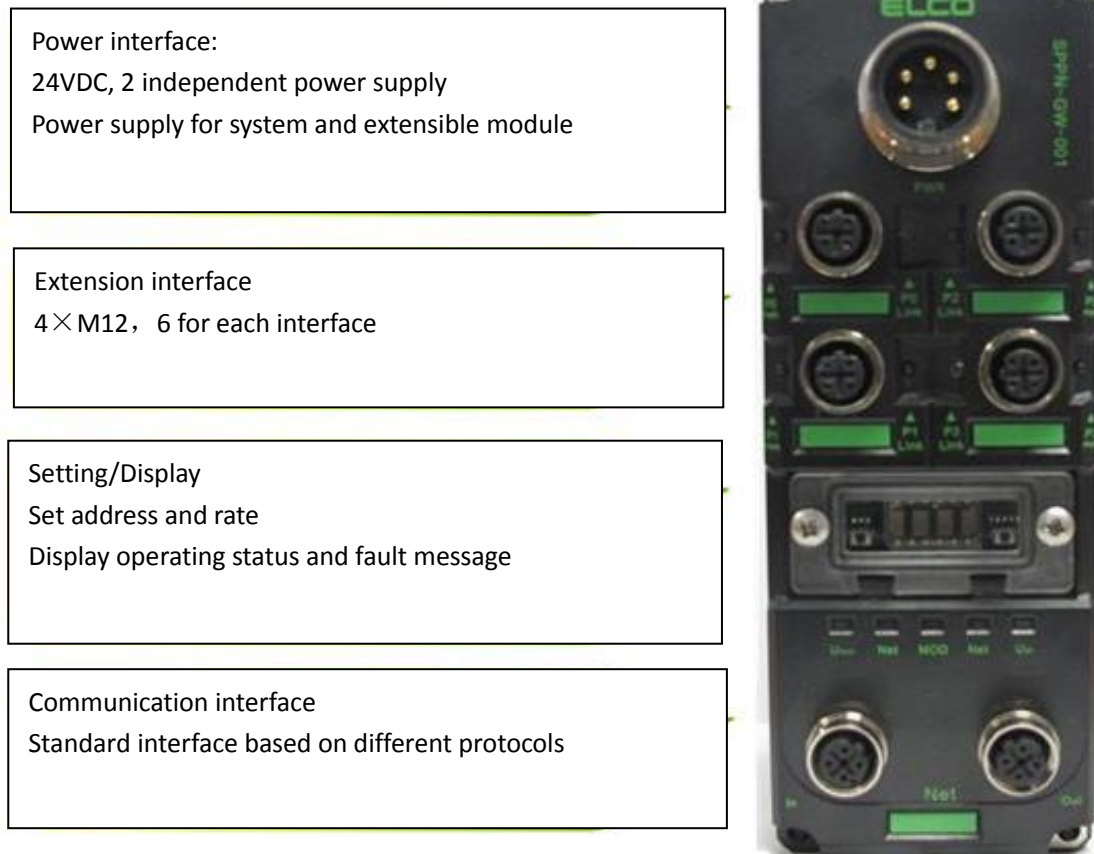

Each Spider67 takes a slave address, extending up to 4-port I/O module connection, max. 6 I/O modules for each port, extension distance up to 100m.

Spider67, as the slave of EtherNet/IP, assigns the device name and its IP address, and can also to be allocated IP address by PLC according to the network topology. Each Spider67 can connect max. 24 I/O modules by extension interface. Modules are allocated to 1~24 in light of extension interface (P0-P1-P2-P3) and the distance to the gateway, and are configured by programming software (see 4.4). If the number of connected modules is less than 6, then the number of the module will be brought forward automatically. For example, P0 connects 3 modules, the number of 1<sup>st</sup> module of P1 interface is 4.



## 2.2 I/O module

The picture is the schematic of a Spider67 I/O module.

Extension interface  
In/out, serial  
1 cable for communication and power supply

I/O interface:  
4 × M12  
8 × M8



I/O modules of Spider67 are serial connected, and are connected to In of 1<sup>st</sup> module by extension cable, then Out of 1<sup>st</sup> module to In of 2<sup>nd</sup>, up to 4 modules.

Spider67 I/O modules are designed by the same housing dimensions, including digital, analog, input and output, only two different interfaces, 4×M12 and 8×M8. M12 A-Code, 2 digital or 1 analog are available. M8, 3-pin, 1 digital is available.

### **2.3 Extension cable**

Spider67 extension cable is used between gateways and I/O modules. The overall cable length from the extension interface to the last module is less than 100m .

P01 series cable is the standard extension cable. P09 series long distance communication cable is recommended if the extension distance is over 10m or high load current, P03 series flexible communication cable is especially used for bending lifespan like drag chain (see 1.4)

Terminal resistance is recommended to eliminate reflection and echo, which are used to prevent discontinuous extensible cable resistance or interference caused by long distance communication. As Spider67 is installed terminal resistance, users need to connect a resistance to Out of the last module of each extension interface.

## 2.4 Hardware parameters

### 2.4.1 Technical data of gateway

Type	SPPN-GW-001
Extensible channel	4 (P0~P3)
Extensible module/channel	4
Extension distance	Max. 100m
EtherNet/IP input	D-Code M12 (Female)
EtherNet/IP output	D-Code M12 (Female)
Extension channel	B-Code M12 (Female)
Power input	7/8" (Male,)
$U_{MOD}$	24VDC (18~30V)
$U_{SP}$	24VDC (18~30V)
Operation current	<200mA
Max. output current	6A/channel, total for gateway 8A
Operation temperature	-25°C ...70°C
Storage temperature	-40°C ...85°C
Shock resistance grade	Comply with IEC60068-2-6
EMC	EN 61000-6-2
Protection class	IP67
Operating life	100,000 hours

## 2.4.2 Digital IO Module

Type	SPDB-0800D-001 SPDB-0800D-011 SPDB-0800D-003 SPDB-0800D-013	SPDB-0404D-001 SPDB-0404D-011 SPDB-0404D-003 SPDB-0404D-013	SPDB-08UP-001 SPDB-08UP-011	SPDB-0008D-001 SPDB-0008D-011	SPDB-0006D-001
Input points	8	4	Max 8	0	0
Output points	0	4	Max 8	8	6
Extension input	B-Code M12 (Male)				
Extension output	B-Code M12 (Female)				
Input and output Signal	A-Code M12 (Female)				
Maximum output current	Each channel 0.5A, module 4A				Each channel 2A, Module 8A
Input response frequency	30Hz				
Output voltage	$U_{Sp} -0.7V$				
Signal type	PNP/NPN				
Input point Supply current	Holding current 200mA, Action current 400mA				
Normal input voltage	24VDC (10~30V)				
Operation temperature	-25°C...70°C				
Storage temperature	-40°C...85°C				
Anti-vibration Class	IEC60068-2-6				
Anti-interference EMC	EN 61000-6-2				
Protection class	IP67				
Operating life	100,000 hours				

### 2.4.3 Analog IO Module

Model	SPDB-0300A-001	SPDB-0300A-002	SPDB-0003A-001	SPDB-0003A-002
Input points	3	3	0	0
Output points	0	0	3	3
Extension input	B-Code M12 (Male)			
Extension output	B-Code M12 (Female)			
Input and output Signal	A-Code M12 (Female)			
Input range	0~20mA 4~20mA -20~20mA	0~5V 0~10V -5~5V -10~10V	Null	Null
Output range	Null	Null	0~20mA 4~20mA	0~5V 0~10V -5~5V -10~10V
Internal impedance	<125Ω	<100kΩ	>450Ω	>1kΩ
Resolution	14Bit			
Measurement accuracy	±0.3%			
Input point Supply current	Max. 200mA			
Operation temperature	-25°C...70°C			
Storage temperature	-40°C...85°C			
Anti-vibration Class	IEC60068-2-6			
EMC	EN 61000-6-2			
Protection class	IP67			
Operating life	100,000 hours			

## 2.4.4 RTD and TC Module

Model	SPDB-0400A-005	SPDB-0400A-006
Input points	4	
Output points	0	
Extension input	B-Code M12 (Male)	
Extension output	B-Code M12 (Female)	
Input and output Signal	A-Code M12 (Female)	
Input range	PT100,PT200,PT500,PT1000 Ni100,Ni1000 0~150/300/600/3000Ω	Type B, E, J, K, N, R, S, T
Output range	Null Null	
Internal impedance	250Ω	1MΩ
Resolution	14Bit	
Measurement accuracy	±0.2%	
Input point Supply current	Max. 200mA	
Operation temperature	-25°C...70°C	
Storage temperature	-40°C...85°C	
Anti-vibration Class	IEC60068-2-6	
EMC	EN 61000-6-2	
Protection class	IP67	
Operating life	100,000 hours	

## 2.5 LED display

Gateway display

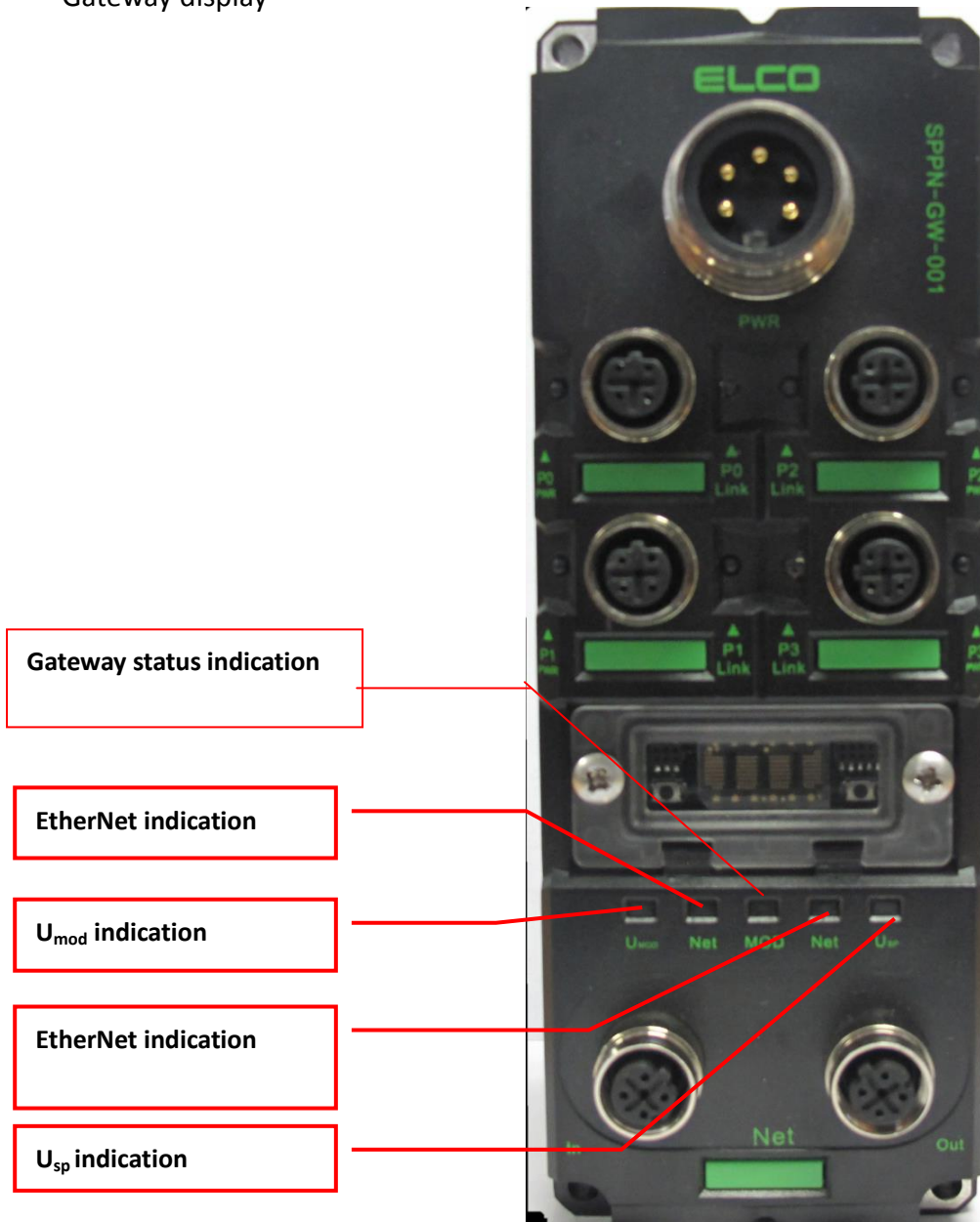

I/O module display

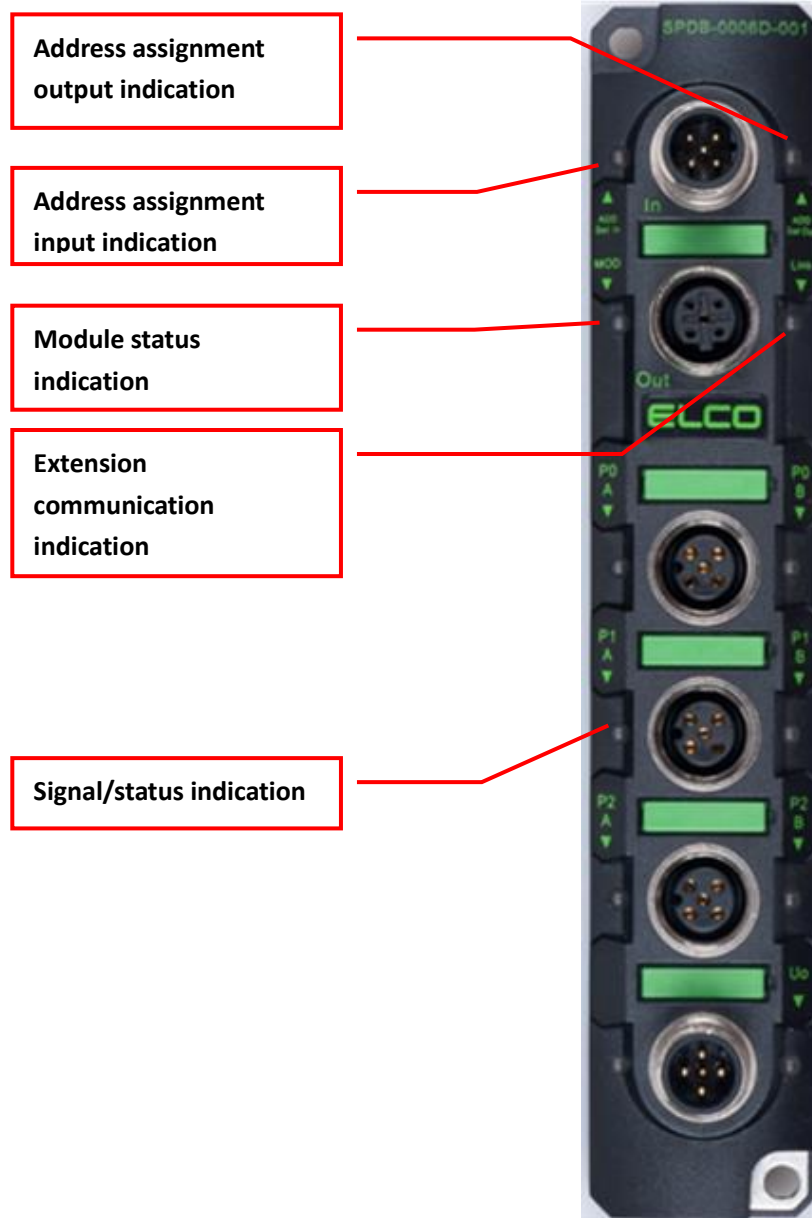



### 3. Installing

#### 3.1 Mounting dimensions

##### 3.1.1 Gateway dimensions

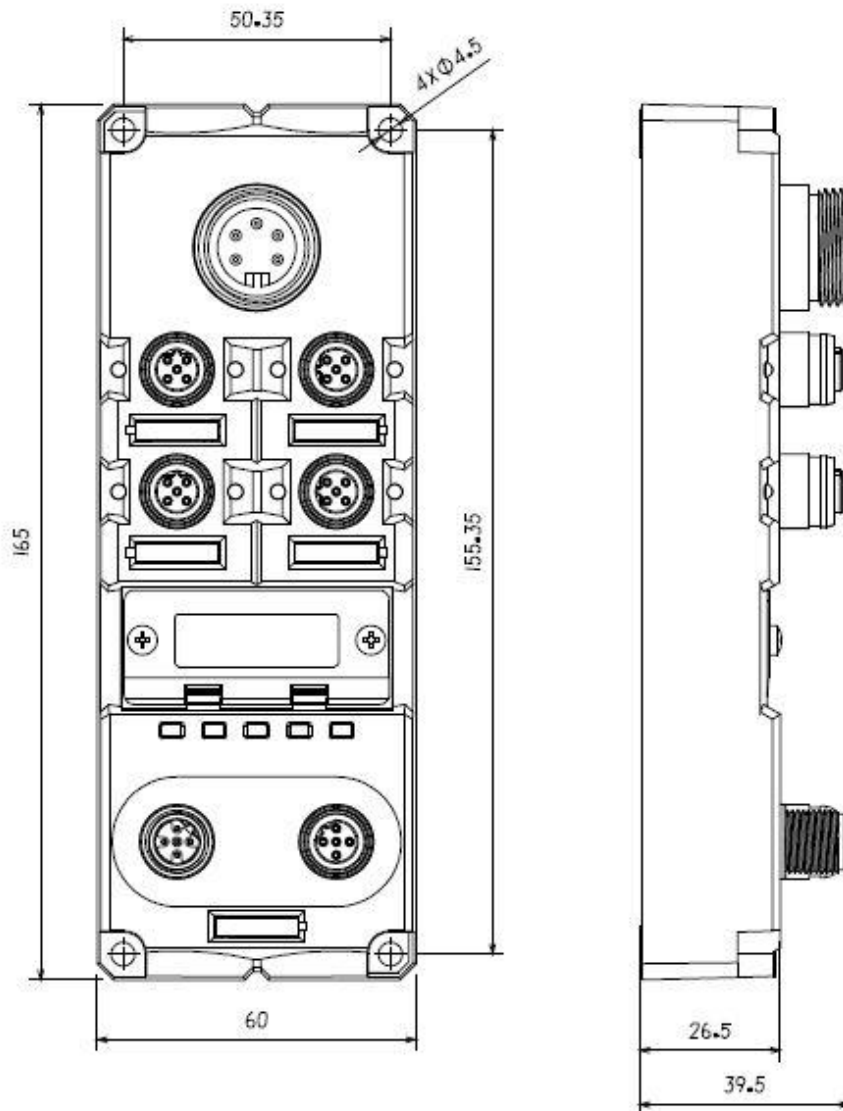

### 3.1.2 Module dimensions

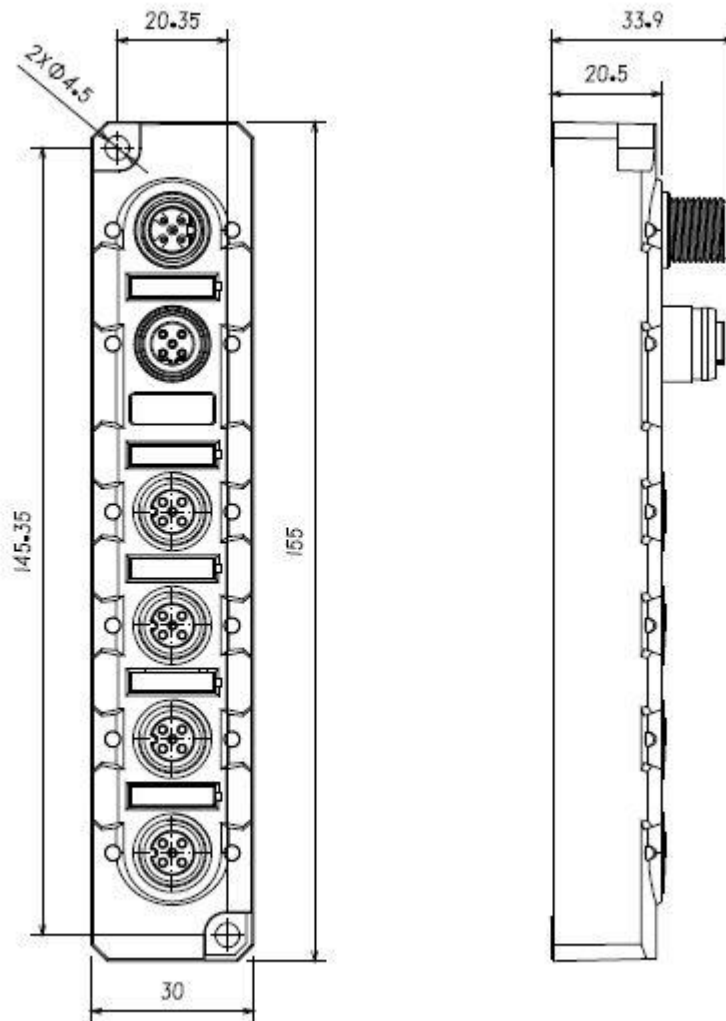

### 3.2 Mounting position and dimensions

Spider67 can be mounted in any position.

The following table shows the mounting dimensions of Spider67 gateway and I/O module.

	Gateway	I/O module
Mounting width	60mm	30mm
Mounting height	165mm	155mm
Mounting depth	39mm (without connector)	33.5mm (without connector)

### 3.3 Setting the IP Address of Spider67 Gateway

Before using the EtherNet/IP Spider67 gateway, you need to use the DHCP server of Rockwell software to assign IP addresses.

First open the BOOP-DHCP server, click on Tools->Network Settings to set the network parameters and fill in the Subnet Mask.

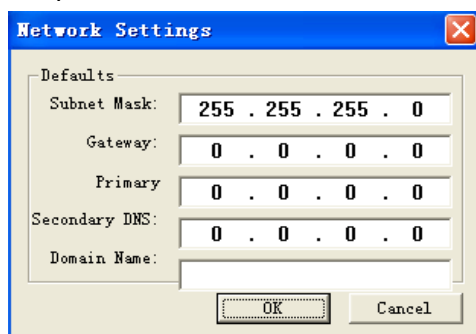

Then the DHCP server will find current gateway that has no IP address assigned on the network, and then click the gateway MAC address that needs to be assigned IP. **If the Spider67 gateway disables BOOTP and DHCP, it may not be found automatically. You need to click the New button to manually add the MAC address.**

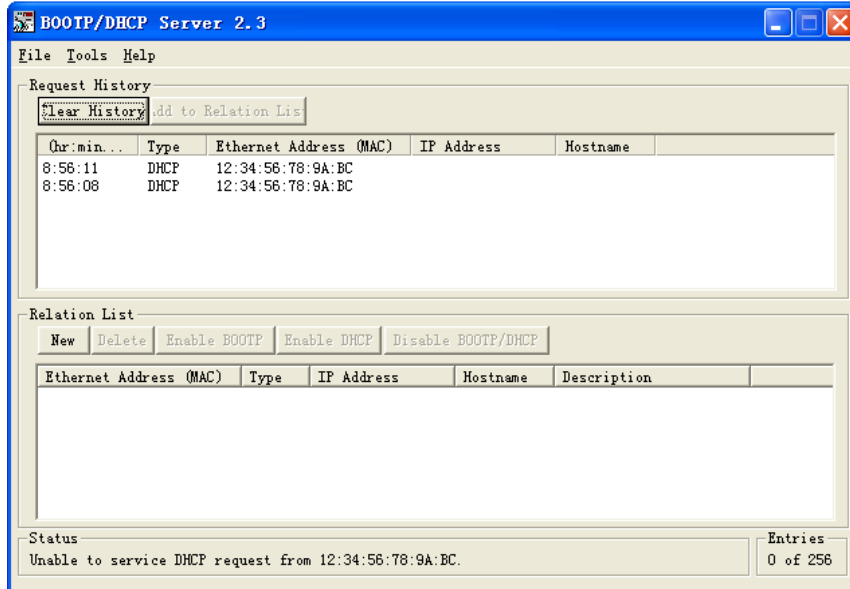

Then click Add to Relation List, or double-click MAC address, in the pop-up window, fill in IP address in IP bar, such as 192.168.1.108.

Note: the assigned IP address needs to be in the same IP segment as the local computer.

As follows:

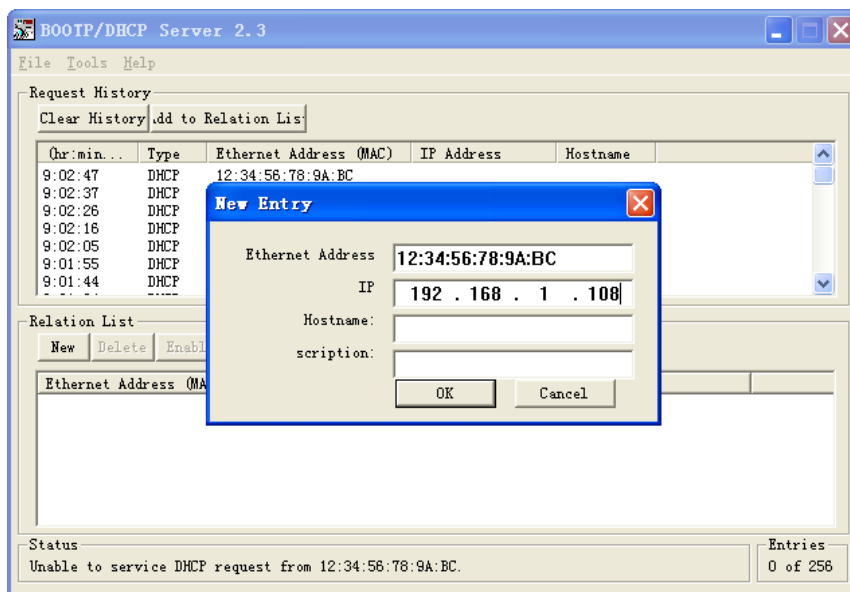

After the assigned IP address appears in the IP Address column in the list, the IP address of the device is assigned successfully. As follows:

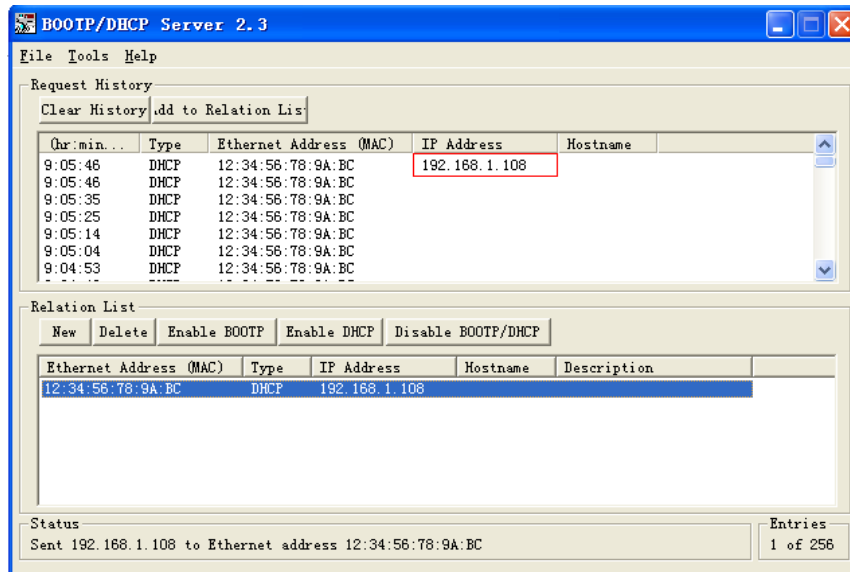

After the IP address is assigned, the device can work normally on the network. However, if the device is powered off and restarted, the assigned IP address will be lost. Follow the above steps to process IP address allocation. If the IP address to be distributed is solidified to the gateway and its power-off IP address is not lost, you need to click the Disable BOOTP/DHCP button in the following figure. After the Command Successful appears in the Status column, the IP address is successfully solidified. If you click the Status column and there is no success message, you need to click again until the command succeeds. As follows:

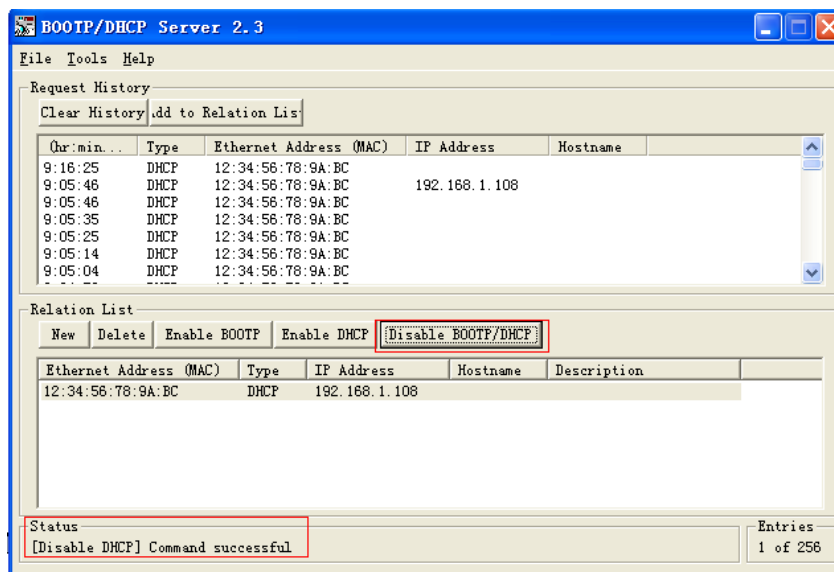

### 3.4 Wiring Spider67

Please make sure to cut off power supply when wiring to ensure safety.

#### 3.4.1 Connecting Spider67 to protective earth (PE)

- Always connect the Spider67 to protective earth.
- The module also requires this connection to protective earth in order to discharge any interference currents to ground, and for EMC compatibility.
- Always make sure you have a low-impedance connection to protective earth.

#### 3.4.2 Spider67 power supply

Spider67 series gateway 24VDC power supply, and power I/O module by extensible cable, voltage range 18~30VDC, standard 7/8" connector.

Two parts for power supply: gateway module power supply  $U_{MOD}(1L+, 1M)$ , signal module power supply (2L+, 2M). Electrical isolation between 1L+ and 2L+, internally connected between common point 1M and 2M.

1) Power in (Male)

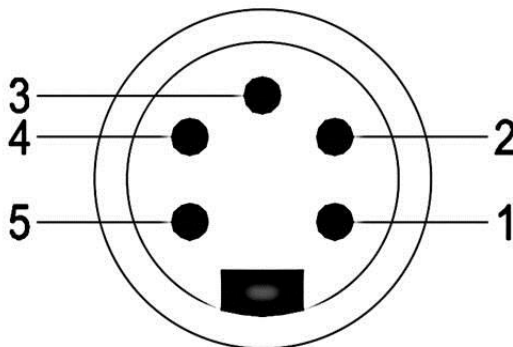

2) Power definition

Terminal	Function	Power supply
1	Signal module power supply 2M	0V
2	Gateway module power supply 1M	0V
3	PE	
4	Gateway module power supply 1L+	24V
5	Signal module power supply 2L+	24V

The six-point output module of Spider67, SPDB-0006D-001 supports auxiliary power supply to the load. The single output point can up to 2A, and the whole module can up to 8A. This power supply interface also uses standard 24VDC power supply and M12 A-Code standard interface.

1) Auxiliary power supply (Male)

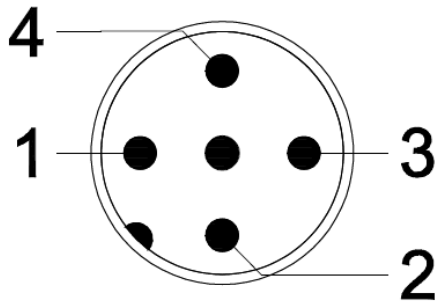

2) Power definition

Terminal	Function	Power supply
1	Auxiliary power supply L+	24V
2	Auxiliary power supply L+	24V
3	Auxiliary power supply M	0V
4	Auxiliary power supply M	0V

**Note:** In order to improve the power supply capability of the interface, it is recommended that all four pins should be connected with power supply. In fact, pin1&2 should be connected together and pin 3&4 should be connected together.

### 3.4.3 Spider67 BUS connection

Spider67 gateway, supporting EtherNet/IP protocol, transmits signals by a shielded cable, D-Code M12 connector.

#### 1) BUS-In (Female)

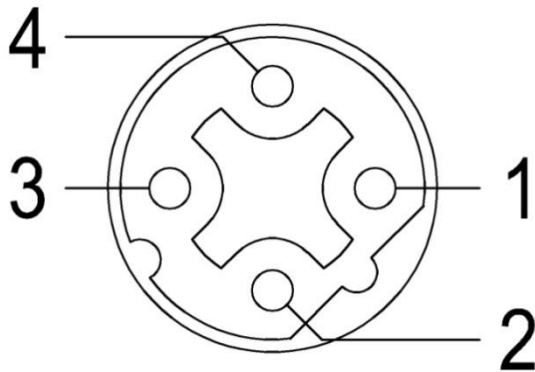

#### 2) BUS-Out (Female)

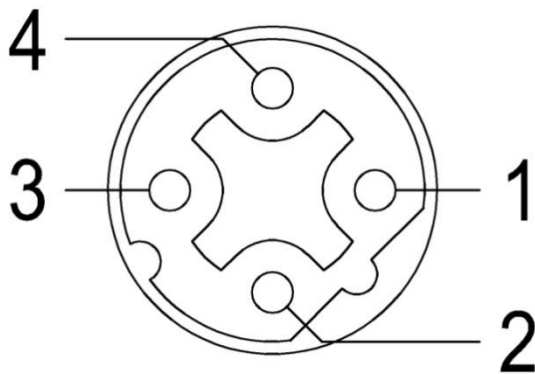

#### 3) Bus definition

Terminal	Function	Cable color
1	Transmit Data( TD+ )	Yellow
2	Receive Data( RD+ )	White
3	Transmit Data( TD- )	Orange
4	Receive Data( RD- )	Blue



### 3.4.4 Spider67 digital signal connection

Spider67 digital I/O modules are connected by standard 5-pin M12 or 3-pin M8 connector, max. 2 signals (input or output) can be connected to M12 interface, 1 signal (input or output) can be connected to M8 interface.

#### 1) Signal receiving (Female)

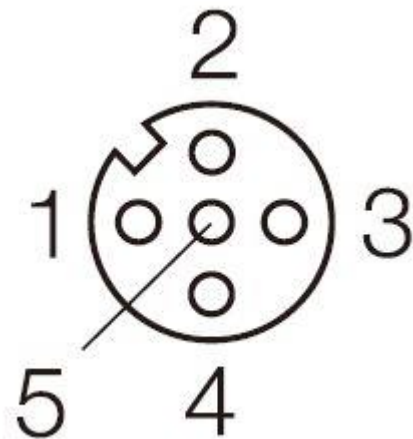

**M12 connector**

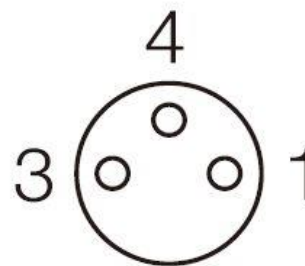

**M8 connector**

#### 2) Digital signal interface definition

Terminal	M12 connector		M8 connector
1	Power supply 24V+		Power supply 24V+
2	Signal in/out B	2 <sup>nd</sup> signal	None
3	Power supply GND		Power supply GND
4	Signal in/out A	1 <sup>st</sup> signal	Signal in/out
5	PE		None

### 3) Wiring example

- a) Double input signal – 1 connector connects 2 DI, SPDB-0800D-001, SPDB-0404D-001, and SPDB-08UP-001 support this connection.

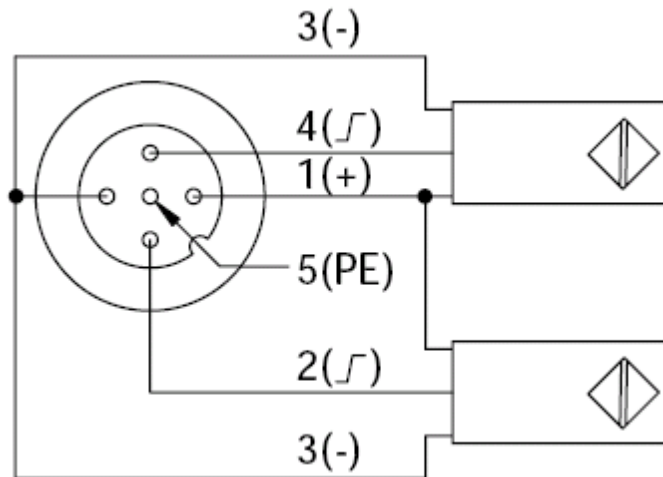

- b) Double output signal – 1 connector connects 2 DO, SPDB-0008D-001, SPDB-0404D-001, SPDB-08UP-001, SPDB-0006D-001 support this connection.

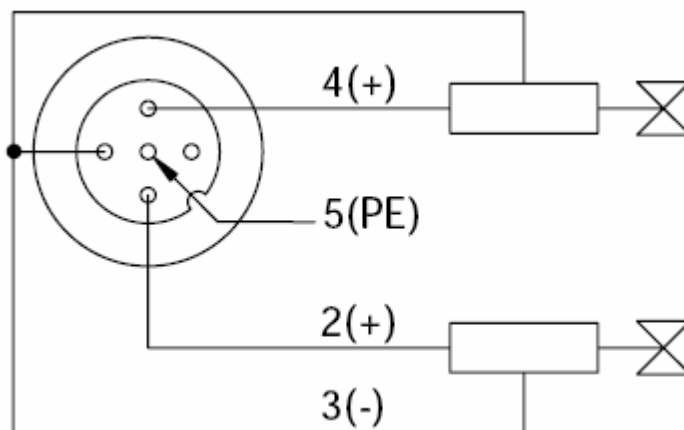

- c) Input and output signal – 1 connector connects 1 DI and 1 DO,  
 SPDB-08UP-001 supports this connection

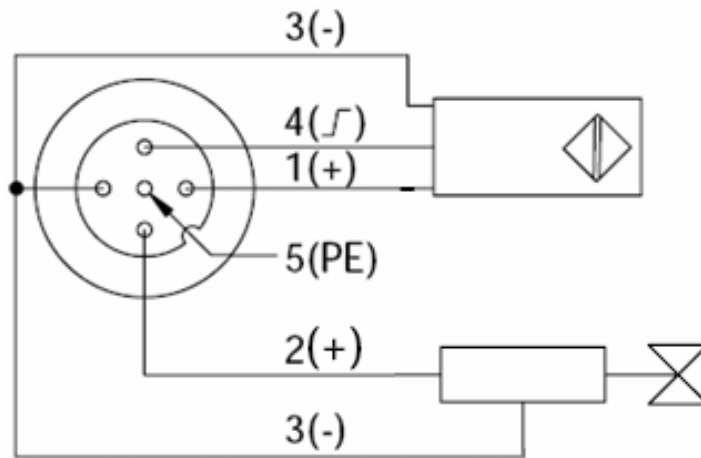

- d) Single input signal – 1 connector connects 1 DI, SPDB-0800D-011,  
 SPDB-0404D-011, SPDB-08UP-011 support this connection.

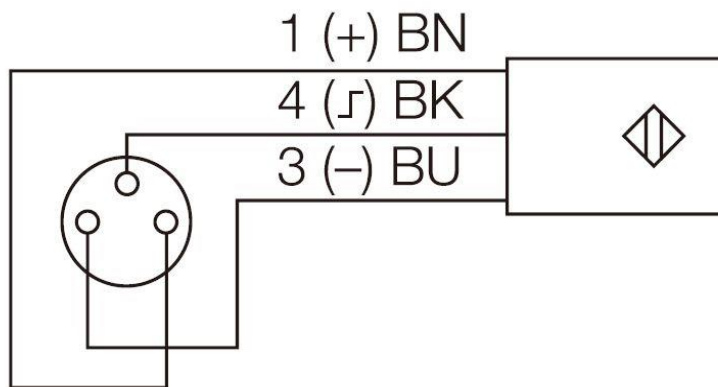

- e) Single output signal – 1 connector connects 1 DO, SPDB-0404D-011,  
 SPDB-0008D-011, SPDB-08UP-011 support this connection.

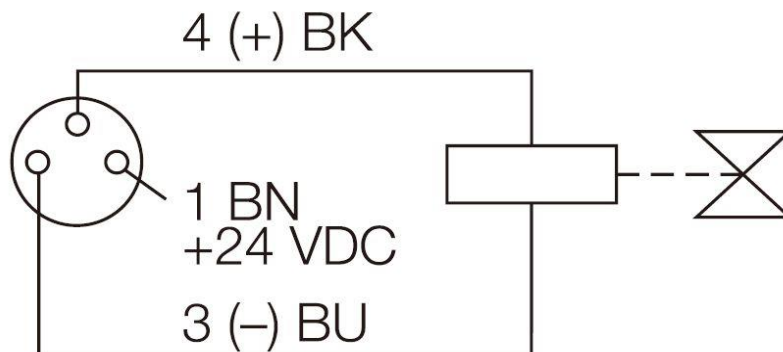

### 3.4.5 Spider67 analog signal

Spider67 analog I/O modules are connected by standard 5-pin M12, 1 signal (input or output) can be connected to interface.

#### 1) Signal receiving (Female)

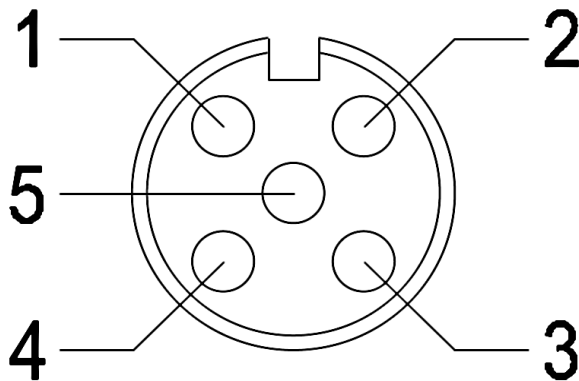

#### 2) Analog signal interface definition

Terminal	Function	Function
1	Power supply 24V+	
2	Signal in/out +	AI/AO +
3	Power supply GND	
4	Signal in/out -	AI/AO -
5	PE	

#### RTD and TC signal interface definition

Terminal	Function	Function
1	Power supply I+	
2	Signal in M+	RTD/TC +
3	Power supply I-	
4	Signal in M-	RTD/TC -
5	PE	

### 3) Wiring example

- a) 2-wire input - 1 connector connects 1 2-wire input, SPDB-0300A-001 supports this connection.

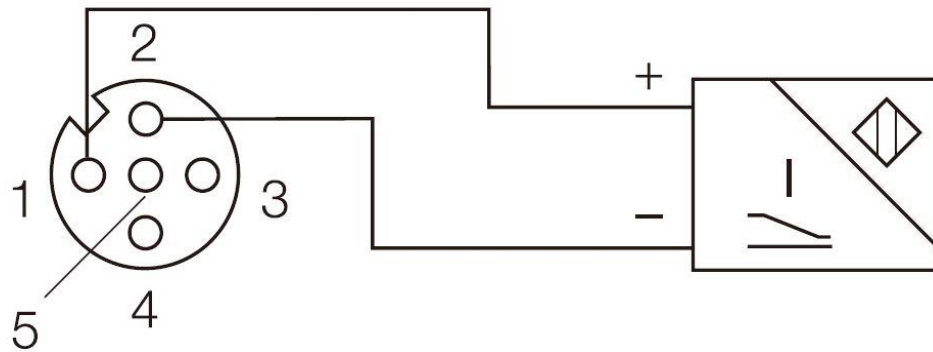

- b) 4-wire input - 1 connector connects 1 4-wire input, SPDB-0300A-001 supports this connection.

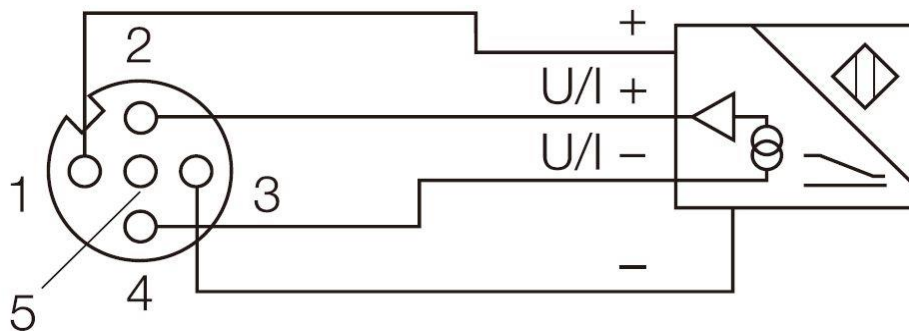

- c) Voltage input- 1 connector connects 1 voltage input, SPDB-0300A-002 supports this connection.

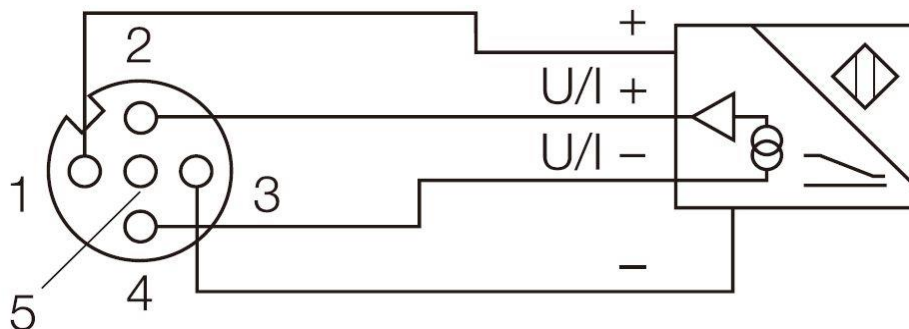

d) Current output- 1 connector connects 1 current output, SPDB-0003A-001 supports this connection.

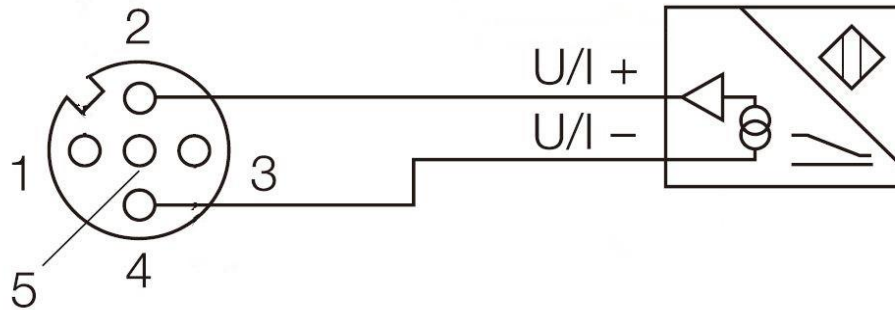

e) Voltage output- 1 connector connects 1 voltage output, SPDB-0003A-002 supports this connection.

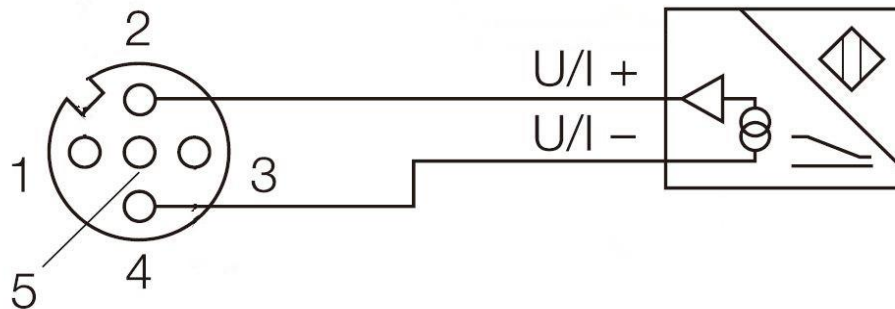

f) Two-wire thermal resistance signal — 1 connector connects 1 two-wire thermal resistance input signal, the model SPDB-0400A-005 of the signal module supports this form of connection.

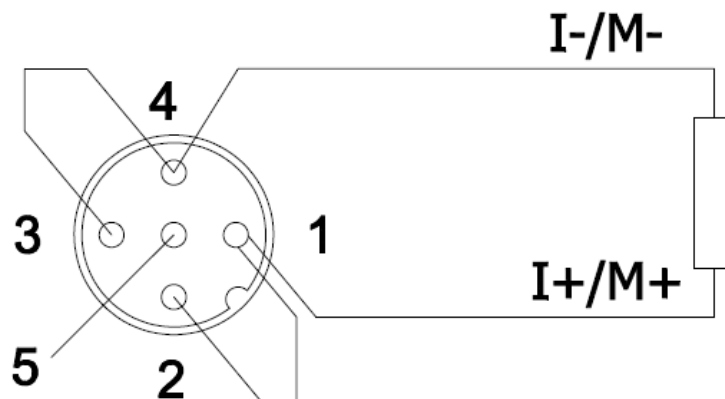

g) Three-wire thermal resistance signal — 1 connector connects 1 three-wire thermal resistance input signal, the model SPDB-0400A-005 of the signal module supports this form of connection.

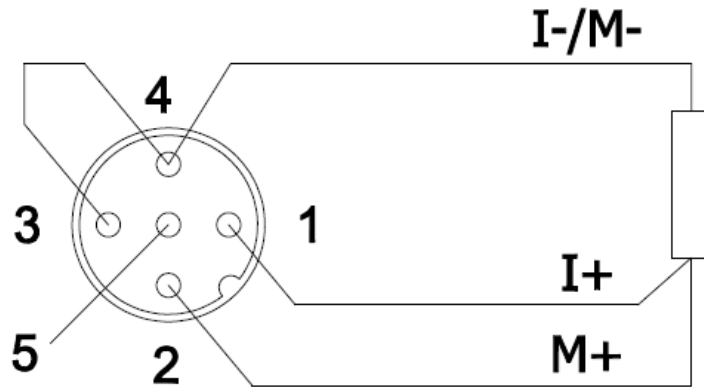

h) Four-wire thermal resistance signal — 1 connector connects 1 four-wire thermal resistance input signal, the model SPDB-0400A-005 of the signal module supports this form of connection.

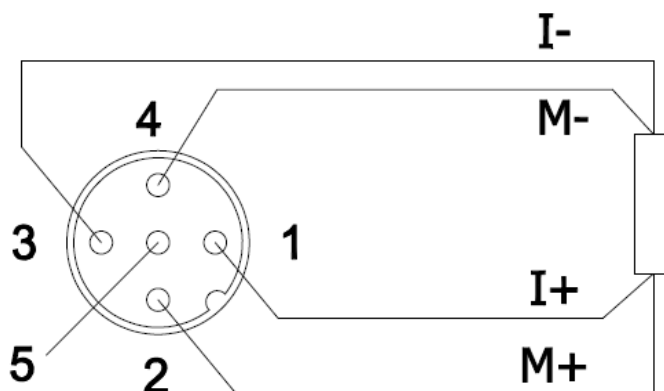

i) Thermocouple signal — 1 connector connects 1 thermocouple input signal, the model SPDB-0400A-006 of the signal module supports this form of connection.

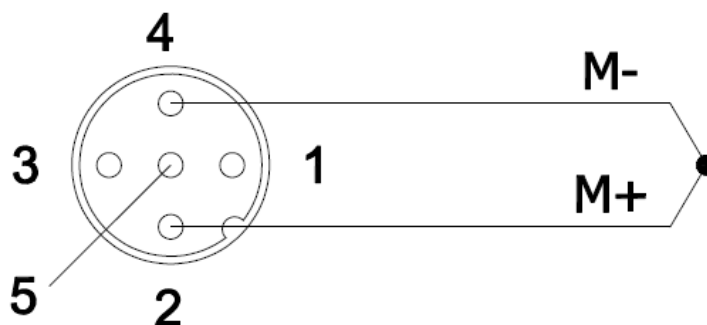

## 4. Configuration Commissioning

### 4.1 Gateway assigns IP address

For reference, the IP address of the Spider67 gateway is allocated in Section 3.3.

### 4.2 RSLink set up link classes

Open the RSLink, click the menu bar Communications->Configure Drivers, and pop up as follows window:

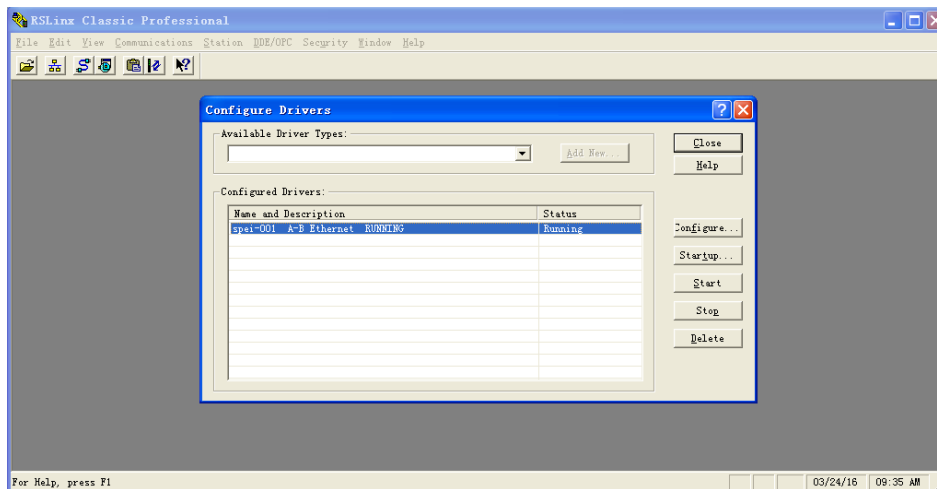

Select EtherNet/IP Driver from Driver Types, then click Add New... , and take a name for yourself , click OK, select the default, click confirm, Status is Running.

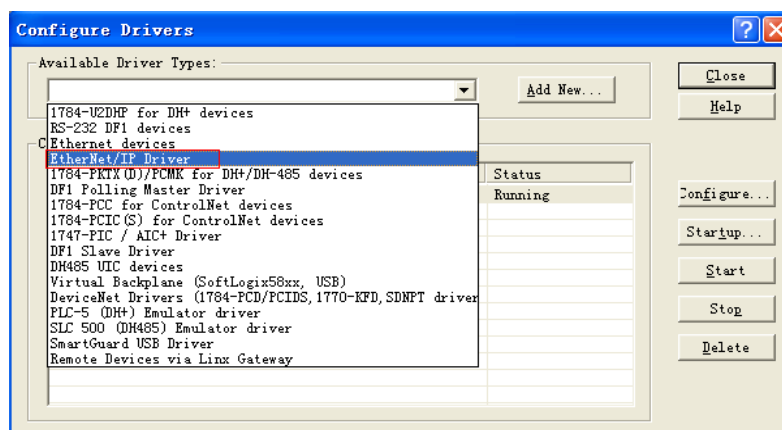



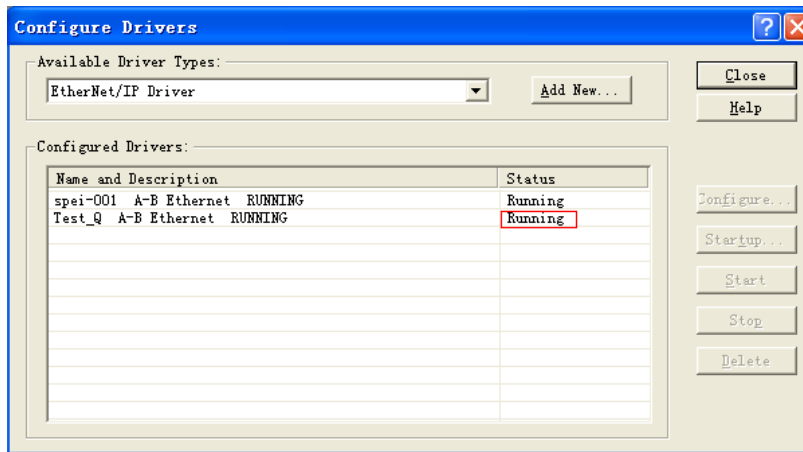

### 4.3 Set up network configuration

Open the RSNetWorx for EtherNet/IP network scanning configuration software.

#### 4.3.1 Import the EDS file

In the RSNetWorx menu bar, click Tools->EDS Wizard... , and then click next. Select to register EDS, click next, select EDS file SPEI-GW-001.eds, and then next. After the EDS file is imported successfully, we can see our company's Spider67 device on the left side of RSNetWorx software. As follows:

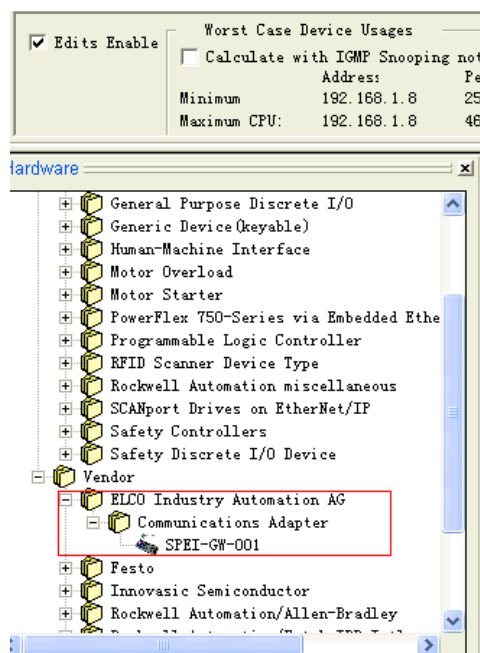

### 4.3.2 Scan network device

Access Spider67 gateway device and PLC device to the network, then click the RSNetWorx menu column NetWork->online, or click the icon below to scan the device in the network.



For example, the scanning result is as follows:

The network has a PLC and 3 Spider67 gateway devices, and the IP address of the corresponding devices.

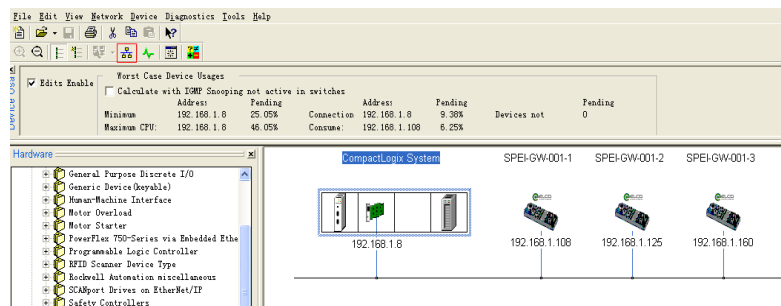

## 4.4 RSLogix5000

Use RSLogix5000 software to configure EtherNet/IP I/O hardware configuration, allocation and programming.

### 4.4.1 Set up RSLogix5000 project

Set up a new project, select the model, version, project name of EtherNet/IP PLC. As follows:

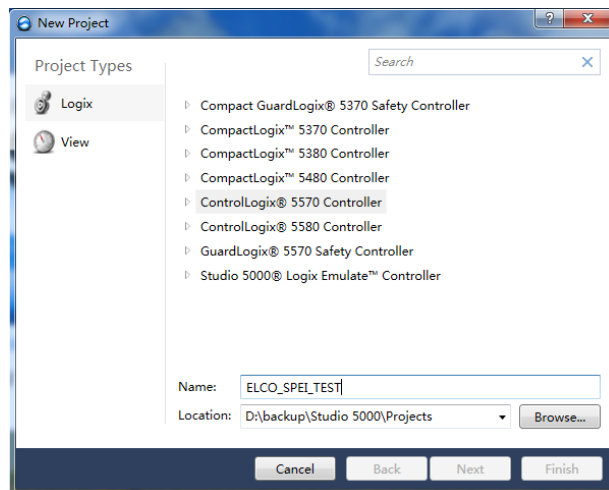

In the newly set up RSLogix5000 project, double-click the model of the PLC device in the following figure, and enter the IP address of the PLC device at the IP address of the pop-up window.

Switch the label above the window to RSNetWorx, then select the file configured in the RSNetWorx network, click OK.

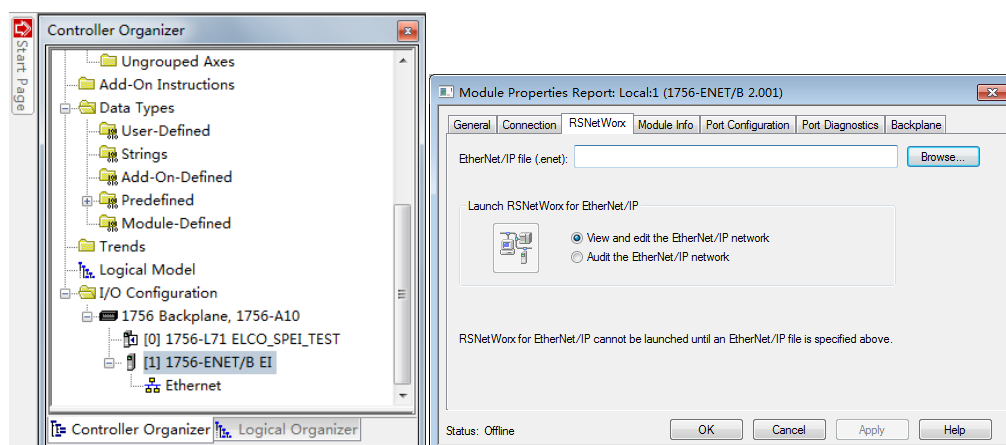

#### 4.4.2 Add Spider67 gateway module and configure I/O size.

Right click Ethernet, select New Module, select ETHERNET-MODULE, and then click set up. As follows:

Catalog Number	Description	Vendor	Category
E1 Plus	Electronic Overload Relay Communications ...	Allen-Bradley	Communication
E121...	Flowserve 208Vac/240Vac/325Vdc	Reliance EL...	DPI to EtherNe
E141...	Flowserve 400Vac/480Vac/650Vdc	Reliance EL...	DPI to EtherNe
E151...	Flowserve 600Vac/810Vdc	Reliance EL...	DPI to EtherNe
EtherNet/IP	SoftLogix5800 EtherNet/IP	Allen-Bradley	Communication
ETHERNET-BRIDGE	Generic EtherNet/IP CIP Bridge	Allen-Bradley	Communication
<b>ETHERNET-MODULE</b>	<b>Generic Ethernet Module</b>	<b>Allen-Bradley</b>	<b>Communication</b>
ETHERNET-PANELVIEW	EtherNet/IP Panelview	Allen-Bradley	HMI
ETHERNET-SAFETY-ST...	Generic EtherNet/IP Safety and Standard M...	Allen-Bradley	Safety, Other
EX250-SEN1	Ethernet Valve Manifold SIU	SMC Corpora...	Communication
EX260-SEN1	Ethernet Valve Manifold SIU	SMC Corpora...	Communication
EX260-SEN2	Ethernet Valve Manifold SIU	SMC Corpora...	Communication
EX260-SEN3	Ethernet Valve Manifold SIU	SMC Corpora...	Communication

Pop-up the following window:

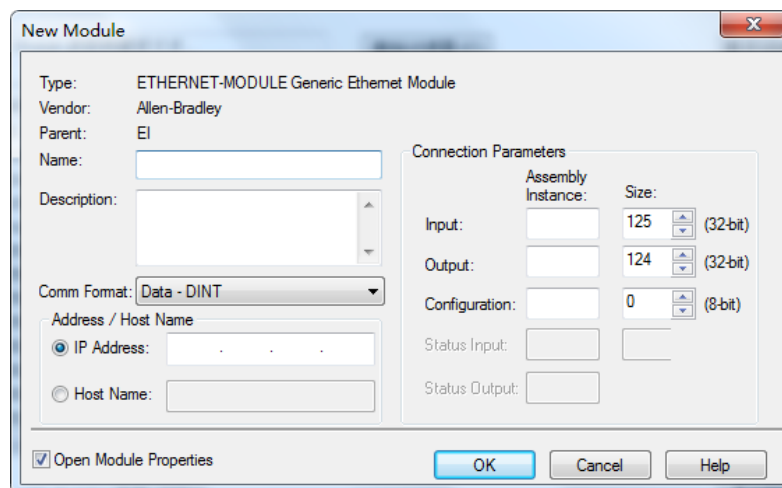

The 'New Module' dialog box is shown with the following configuration:

- Type: ETHERNET-MODULE Generic Ethernet Module
- Vendor: Allen-Bradley
- Parent: EI
- Name: (empty text box)
- Description: (empty text box)
- Comm Format: Data - DINT
- Address / Host Name:
  - IP Address: . . .
  - Host Name: (empty text box)
- Connection Parameters:
  - Input: (empty text box) 125 (32-bit)
  - Output: (empty text box) 124 (32-bit)
  - Configuration: (empty text box) 0 (8-bit)
  - Status Input: (empty text box)
  - Status Output: (empty text box)

Buttons:  Open Module Properties, OK, Cancel, Help

I/O module is configured as follows:

- **Name:** user defined module name will be used in the programming label. For example, enter SPEI\_01;
- **Comm (communication format):** select Data-SINT;
- **IP Address:** enter the IP address of the Spider67 gateway, which is 192.168.1.108 of the example.

● **Connection parameters:** I/O parameter device

Assembly Instance enter content:

Input is 101

Output is 100

Configuration is 105

The entering of the Size is shown in the following table:

The size of the Input consists of the following:

Status diagnosis content	DI digital input length	AI analog input size
8 Bytes	n Bytes(minimum 0 Byte)	2n Bytes(minimum 0 Byte)

The status diagnosis content is shown in annex table four.

The size of the Output consists of the following:

Gateway control data	DO digital input length	AO analog input size
2 Bytes	n Bytes(minimum 0 Byte)	2n Bytes(minimum 0 Byte)

The gateway control data is shown in annex table one.

The size of configuration is fixed value: 64

For example, Spider67 has received 4 I/O digital modules in sequence: M12-8DI, M12-8DO, M12-8UP and M8-8DI. The above configuration data are as follows:

Input:

8 bytes of gateway status diagnostic data occupy 8 Bytes of the input byte.

1\*8DI occupies 1 Byte of input byte;

1\*8UP occupies 1 Byte of input byte and 1 Byte of output byte;

1\*6DI occupies 1 Byte of input byte;

Therefore Input Size = 8 Bytes + 3 Bytes = 11 Bytes

Output:

2 bytes of gateway control data occupy 2 Bytes of output byte.

1\*8DO occupies 1 Byte of output byte;

1\*8UP occupies 1 Byte of input byte and 1 Byte of output byte.

Therefore Output Size = 2 Bytes + 2 Bytes = 4 Bytes

Configuration:

Fixed value: 64 Bytes;  
 Therefore Configuration Size =64 Bytes

After completing the data calculation, fill in the result in the Size column and see the following figure:

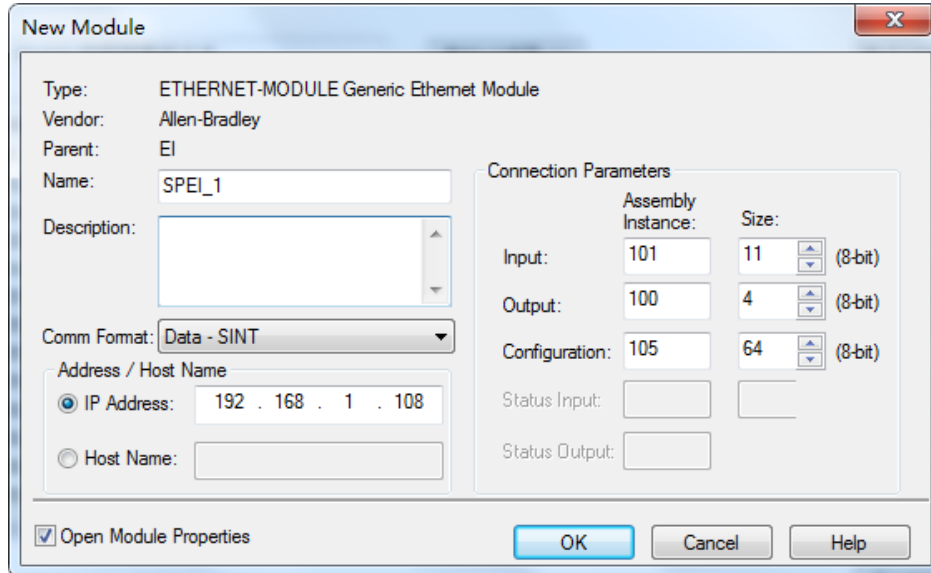

When the gateway is configured, click OK.

#### 4.4.3 Hardware configuration of module configuration

After the module is added, open the "controller label" on the left, you can see that the monitoring Tag on the right side appears three sets of data named after the module name, C.Data, I.Data, and O.Data, as follows:

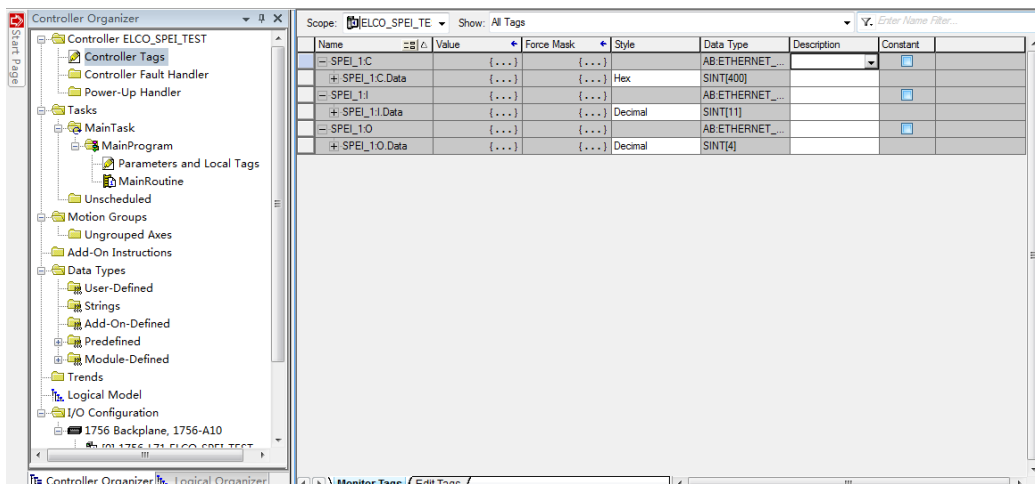

Open the C.Data and enter the module configuration data under the gateway.

Example 1, digital module configuration, as follows:

[-] SPEI:C.Data	{...}	{...}	Hex	SINT[400]
[+] SPEI:C.Data[0]	16#01		Hex	SINT
[+] SPEI:C.Data[1]	16#02		Hex	SINT
[+] SPEI:C.Data[2]	16#03		Hex	SINT
[+] SPEI:C.Data[3]	16#0a		Hex	SINT
[+] SPEI:C.Data[4]	16#00		Hex	SINT
[+] SPEI:C.Data[5]	16#00		Hex	SINT
[+] SPEI:C.Data[6]	16#00		Hex	SINT

C.Data[0] The type of the first module is filled in in this register ,

M12-8DI is 0x01

C.Data[1] The type of the second module is filled in in this register ,

M12-8DO is 0x02

C.Data[2] The type of the third module is filled in in this register ,

M12-8UP is 0x03

C.Data[3] The type of the fourth module is filled in in this register ,

M8-8DI is 0x0a

The data for the module type corresponds to the annex, table two.

Example two, the analog module configuration is as follows:

[-] SPEI:C	{...}	{...}		AB:ETHERNET_...
[-] SPEI:C.Data	{...}	{...}	Hex	SINT[400]
[+] SPEI:C.Data[0]	16#10		Hex	SINT
[+] SPEI:C.Data[1]	16#14		Hex	SINT
[+] SPEI:C.Data[2]	16#11		Hex	SINT
[+] SPEI:C.Data[3]	16#15		Hex	SINT
[+] SPEI:C.Data[4]	16#05		Hex	SINT
[+] SPEI:C.Data[5]	16#04		Hex	SINT
[+] SPEI:C.Data[6]	16#05		Hex	SINT
[+] SPEI:C.Data[7]	16#04		Hex	SINT
[+] SPEI:C.Data[8]	16#05		Hex	SINT
[+] SPEI:C.Data[9]	16#05		Hex	SINT
[+] SPEI:C.Data[10]	16#01		Hex	SINT
[+] SPEI:C.Data[11]	16#00		Hex	SINT
[+] SPEI:C.Data[12]	16#01		Hex	SINT
[+] SPEI:C.Data[13]	16#01		Hex	SINT
[+] SPEI:C.Data[14]	16#00		Hex	SINT
[+] SPEI:C.Data[15]	16#01		Hex	SINT

C.Data[0] The type of the first module is filled in in this register ,  
current -3AI is 0x10

C.Data[1] The type of the second module is filled in in this register ,  
current -3AO is 0x14

C.Data[2] The type of the third module is filled in in this register ,  
voltage -3AI is 0x11

C.Data[3] The type of the fourth module is filled in in this register ,  
voltage -3AO is 0x15

C.Data[4], C.Data[5] and C.Data[6] are the first analog module “current -3AI’s”  
configuration data.

The configuration structure is as follows:

C.Data[4]	C.Data[5]	C.Data[6]
P0 channel	P1 channel	P2 channel

In the figure

C.Data[4] = 0x05, the current which enters the first channel of the module is  
configured to be 4-20mA.

C.Data[5] = 0x04, the current which enters the second channel of the module is  
configured to be 0-20mA.

C.Data[6] = 0x05, the current which enters the third channel of the module is  
configured to be 4-20mA.

From C.Data[7] to C.Data[15] analog configuration data structure is the same, and  
are the configuration information of the other analog module channels, and the  
specific configuration data is shown in annex table three.

When the configuration data is completed, download to PLC, the configuration data  
will take effect in time.

Note: configuration data need to be completed in software offline.



#### 4.5 Module startup process

The power up to start the Spider67 gateway module is as follows:

- After power on, the device name of the Spider67 gateway will be displayed on the scrollingLED screen and MOD indicator red.
- After the gateway detects the normal link to Ethernet, the scrollingLEDscreen will display FREE+IP address, such as FREE 192.168.1.122, NET indicator flicker.
- After the gateway and PLC establish normal data link, the display content is CON+IP address while the MOD lamp turns green.

## 5. Alarm diagnosis

### 5.1 LED fault indicator light

Through the LED indicator light on the Spider67 gateway module, users can quickly and easily determine the current working state of the module.

Gateway LED Indicator Light					Meaning	Solution
U <sub>MOD</sub>	U <sub>SP</sub>	NET	NET	MOD		
Red	—	—	—	—	The power supply voltage of the gateway module is less than 18V	Check the power supply of the module
—	Red	—	—	—	The power supply voltage of the signal module is less than 18V	Check the auxiliary power supply
—	—	—	—	Red	I/O port has short or overload	Check the sensor or load
					The actual configuration of the extended module is incompatible with configuration	Check configuration configuration
					Broken net	Check network links
					Other module failures	Contact with technical support
Green	Green			Red	Ethernet physical link disconnection	Check network links

Module LED Indicator light				Meaning	Solution
ADD <sub>In</sub>	ADD <sub>Out</sub>	Link	MOD		
Red	Red	—	—	Internal address allocation error in extended modules	Reconnect the gateway
—	—	Red	—	Extended module connection error	Check the extended cable connection
				The extended module is configuring communication with the gateway	Wait for recovery
—	—	—	Red	I/O port has short or overload	Check the sensor or load
				The actual configuration of the extended module is incompatible with configuration	Check configuration configuration
				Other module failures	Contact with technical support
Green	Green	Green	Green	Module is ready	—

## 5.2 Error alarm diagnostic information

The gateway has the function of an error alarm. The gateway includes small module communication loss, module power short and output overload. I.Data[0] - I.Data[3] are small module communication loss alarm, each bit represents a module, the bit is 1, indicating that the corresponding small module is off line, the bit is 0, indicating on line. The corresponding relationship between data bits and module addresses is shown in annex table four.

I.Data[4] - I.Data[7] are small module power supply short and output overload, each bit represents a module, the bit is 1, indicating that the corresponding small module has power supply short or output overload alarm. The bit is 0, indicating that the corresponding module does not have an alarm information. The corresponding relationship between data bits and module addresses is shown in annex table four.

**Appendix:**

**Table One:** gateway control data table

<b>O.Data[0]</b>							
Bit7	Bit6	Bit5	Bit4	Bit3	Bit2	Bit1	Bit0
Reserved							
<b>O.Data[1]</b>							
Bit7	Bit6	Bit5	Bit4	Bit3	Bit2	Bit1	Bit0
Reserved							

**Table Two:** type control tables for each module

Module name	Type code	Type description	Notes
SPDB-0800D-001	0x01	M12 8 points input	
SPDB-0008D-001	0x02	M12 8 points output	
SPDB-08UP-001	0x03	M12 8 points configurable	
	0x04		Reserved
SPDB-0006D-001	0x05	M12 6 points output	
	0x06	M12 4 relay output	Reserved
	0x07	M12 high speed count input	Reserved
	0x08		Reserved
SPDB-0404D-001	0x09	M12 4 input 4 output	
SPDB-0800D-011	0x0A	M8 8 points input	
SPDB-0008D-011	0x0B	M8 8 points output	
SPDB-08UP-011	0x0C	M8 8 points configurable	
SPDB-0404D -011	0x0D	M8 4 input 4 output	
	0x0E		Reserved
	0x0F		Reserved
SPDB-0300A-001	0x10	3 channels current input	
SPDB-0300A-002	0x11	3 channels voltage input	
	0x12	4 channels current input	Reserved
	0x13	4 channels voltage input	Reserved
SPDB-0003A-001	0x14	3 channels current output	
SPDB-0003A-002	0x15	3 channels voltage output	
	0x16	4 channels current output	Reserved
	0x17	4 channels voltage output	Reserved
	0x18	3 channels current and voltage	Reserved
	0x19	4 channels current and voltage	Reserved
SPDB-0800D-013	0x1A	M8 8 points can input NPN	
	0x1B	M8 8 points cac output NPN	Reserved
	0x1C	M8 8 points can be configured for NPN	Reserved
SPDB-0404D-013	0x1D	M8 4 input 4 output NPN	
SPDB-0800D-003	0x1E	M12 8 points input NPN	
	0x1F	M12 8 points output NPN	Reserved

	0x20	M12 8 points can be configured for NPN	Reserved
SPDB-0404D-003	0x21	M12 4 input 4 output NPN	
SPDB-0032D-Vxxx	0x22	32 points valve output	
SPDB-0024D-Vxxx	0x23	24 points valve output	
SPDB-0016D-Vxxx	0x24	16 points valve output	
SPDB-0008D-Vxxx	0x25	8 points valve output	
SPDB-0400A-005	0x26	M12 hot resistance	
SPDB-0400A-006	0x27	M12 thermocouple	
	0x28		Reserved
	0x29		Reserved
SPDB-0800D-Mxxx	0x2A	direct outlet line 8 points input	
SPDB-0008D-Mxxx	0x2B	direct outlet line 8 points output	
SPDB-0404D-Mxxx	0x2C	direct outlet line 4 input 4 output	
SPDB-08UP-Mxxx	0x2D	direct outlet line 8 points configurable	
	0x2E		Reserved
	0x2F		Reserved

**Table Three:** module volume channel function configuration table

Type	0x0	0x1	0x2	0x3	0x4	0x5	0x6	0x7
Voltage type	0~10V	-10~+10V	0~5V	-5~+5V	---	---	---	---
Current type	---	---	---	---	0~20mA	4~20mA	-20~+20mA	---
Hot resistance	PT100	PT200	PT500	PT1000	Ni100	Ni200	Ni500	Ni1000
Thermocouple	Type K	Type J	Type N	Type E	Type B	Type S	Type T	Type R

Type	0x8	0x9	0xA	0xB	0xC	0xD	0xE	0xF
Voltage type	---	---	---	---	---	---	---	Closed
Current type	---	---	---	---	---	---	---	Closed
Hot resistance	150Ω Hot resistance	300Ω Hot resistance	600Ω Hot resistance	3000Ω Hot resistance	---	---	---	Closed
Thermocouple	Voltage 1	Voltage 2	---	---	---	---	---	Closed

The analog module configuration starts from the high channel, followed by CH3, CH2, CH1 and CH0.



**Table Four:** relationship between diagnostic data and module address

I.Data[0]							
Bit7	Bit6	Bit5	Bit4	Bit3	Bit2	Bit1	Bit0
The eighth module	The seventh module	The sixth module	The fifth module	The fourth module	The third module	The second module	The first module
I.Data[1]							
Bit7	Bit6	Bit5	Bit4	Bit3	Bit2	Bit1	Bit0
The sixteenth module	The fifteenth module	The fourteenth module	The thirteenth module	The twelfth module	The eleventh module	The tenth module	The ninth module
I.Data[2]							
Bit7	Bit6	Bit5	Bit4	Bit3	Bit2	Bit1	Bit0
The twenty-fourth module	The twenty-third module	The twenty-second module	The twenty-first module	The twentieth module	The nineteenth module	The eighteenth module	The seventeenth module
I.Data[3]							
Bit7	Bit6	Bit5	Bit4	Bit3	Bit2	Bit1	Bit0
Reserved							
I.Data[4]							
Bit7	Bit6	Bit5	Bit4	Bit3	Bit2	Bit1	Bit0
The eighth module	The seventh module	The sixth module	The fifth module	The fourth module	The third module	The second module	The first module
I.Data[5]							
Bit7	Bit6	Bit5	Bit4	Bit3	Bit2	Bit1	Bit0
The sixteenth module	The fifteenth module	The fourteenth module	The thirteenth module	The twelfth module	The eleventh module	The tenth module	The ninth module

I.Data[6]							
Bit7	Bit6	Bit5	Bit4	Bit3	Bit2	Bit1	Bit0
The twenty-four rth module	The twenty-t hird module	The twenty-se cond module	The twenty-fir st module	The twentieth module	The nineteent h module	The eighteent h module	The seventee nth module
I.Data[7]							
Bit7	Bit6	Bit5	Bit4	Bit3	Bit2	Bit1	Bit0
Reserved							